

V-TAC

Meaningful Innovation.

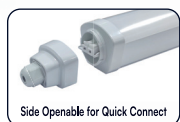

INSTRUCTION MANUAL LED WATERPROOF LAMP



IP65
RATING

6 YEAR
WARRANTY*

TECHNICAL DATA

MODEL	VT-12017	VT-12035	VT-12049
SKU	233916, 233926	233876, 233886	233896, 233906
WATT	18W	36W	48W
LUMEN @SPHERE360°	2160 Lm	4320 Lm	5760 Lm
BEAM ANGLE	120°	120°	120°
DF	≥0.7	≥0.9	≥0.9
CRI	≥80	≥80	≥80
INPUT POWER	AC:220-240, 50/60Hz	AC:220-240, 50/60Hz	AC:220-240, 50/60Hz
LIFE SPAN	50,000 Hours	50,000 Hours	50,000 Hours
ON/OFF CYCLE	25,000 Times	25,000 Times	25,000 Times
MAX CONNECTABLE UNITS	20	10	8
DRIVER MA (Input Current)	90mA	180mA	240mA
MATERIAL	PC	PC	PC
IK RATING	IK05	IK05	IK05
DIMENSION	600x68x59mm	1200x68x59mm	1500x68x59mm

INTRODUCTION & WARRANTY

Thank you for selecting and buying V-TAC product. V-TAC will serve you the best. Please read these instructions carefully before starting the installation and keep this manual handy for future reference. If you have any another query, please contact our dealer or local vendor from whom you have purchased the product. They are trained and ready to serve you at the best. The warranty is valid for 6 years from the date of purchase. The warranty does not apply to damage caused by incorrect installation or abnormal wear and tear. The company gives no warranty against damage to any surface due to incorrect removal and installation of the product. The products are suitable for 10-12 Hours Daily operation. Usage of product for 24 Hours a day would void the warranty. This product is warranted for manufacturing defects only.

WARNING

1. Please make sure to turn off the power before starting the installation.
2. Installation must be performed by a qualified electrician.
3. The light source of this luminaire is not replaceable; when the light source reaches its end of life the whole luminaire shall be replaced.
4. If the external flexible cable or cord of this luminaire is damaged, it shall be exclusively replaced by the manufacturer or his service agent or a similar qualified person in order to avoid a hazard.
5. The control gear of this luminaire is a non-replaceable component; when the control gear reaches its end of life the whole luminaire shall be replaced.
6. Terminal block not included. Must be connected to waterproof terminal box.
7. For indoor use and outdoor use.

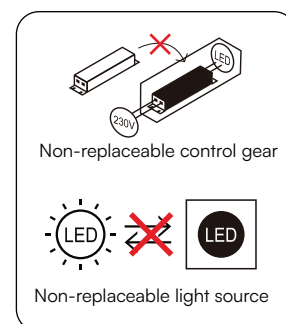

This marking indicates that this product should not be disposed of with other household wastes.



Caution, risk of electric shock.

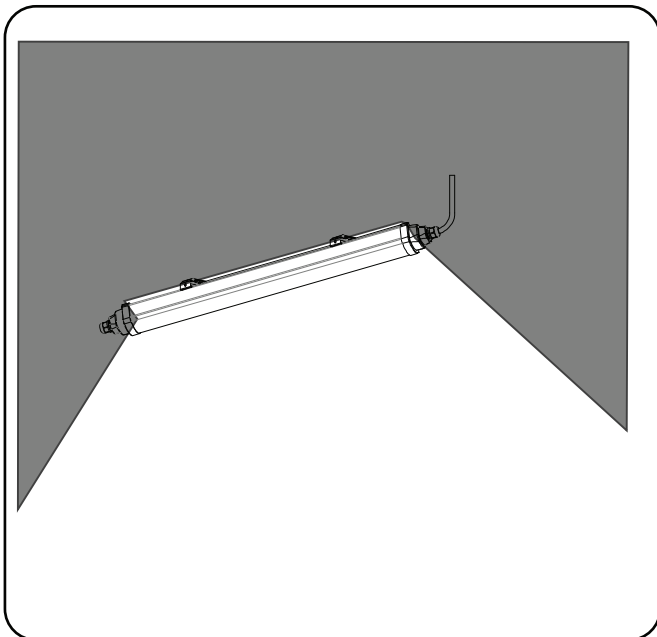
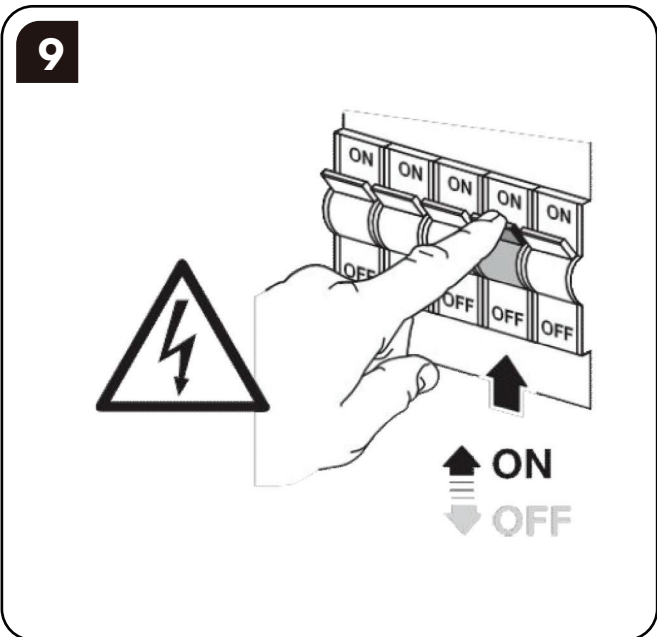
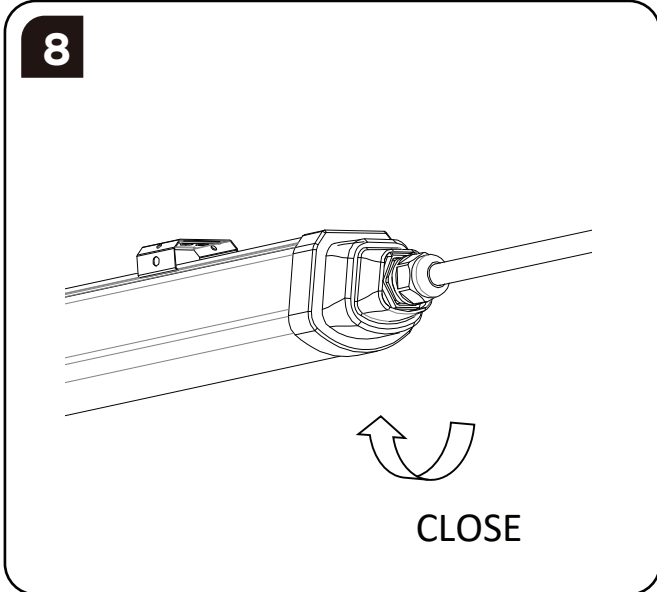
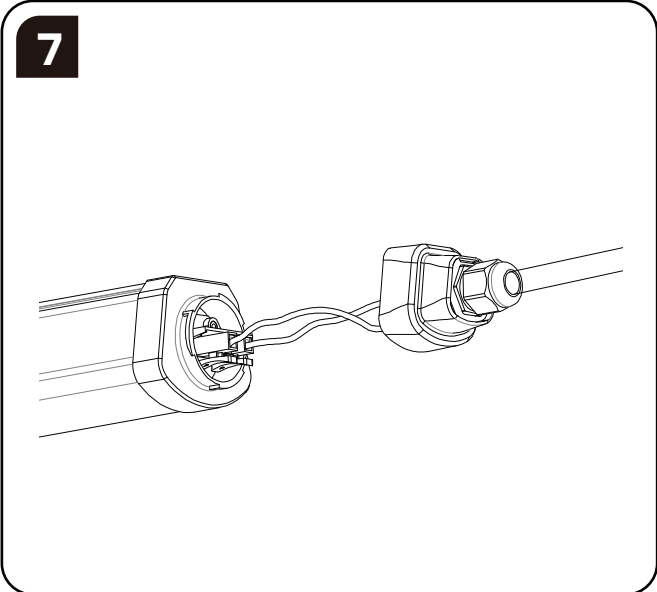
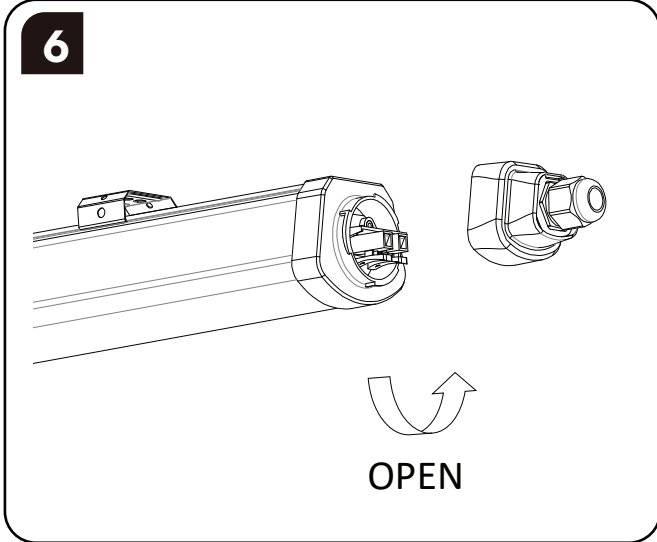
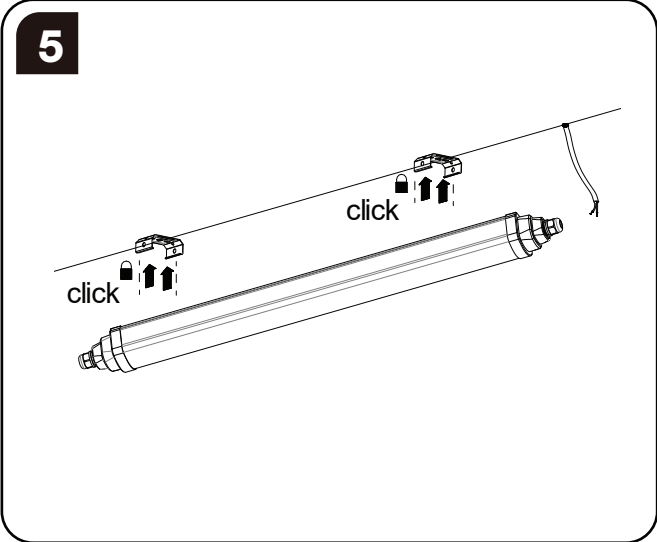

INSTALLATION INSTRUCTION

1. Switch off the power supply before installation.
2. Mark the drilling positions according to the chart.
3. Secure the mounting brackets to the ceiling using the supplied screws. Open the junction box cover on the luminaire body with a screwdriver.
4. Ensure that the cable length is suitable for installation.
5. Mount the luminaire onto the ceiling clips.
6. Open the right-side cover to access the wiring terminal.
7. Insert the cable through the waterproof connector and connect it to the terminal block. Ensure that the Live (L) and Neutral (N) wires are connected correctly:
8. Live (L): Brown
9. Neutral (N): Blue
10. Close and secure the right-side cover.
11. Restore the power supply and test the lamp.

LINKABLE CONNECTION

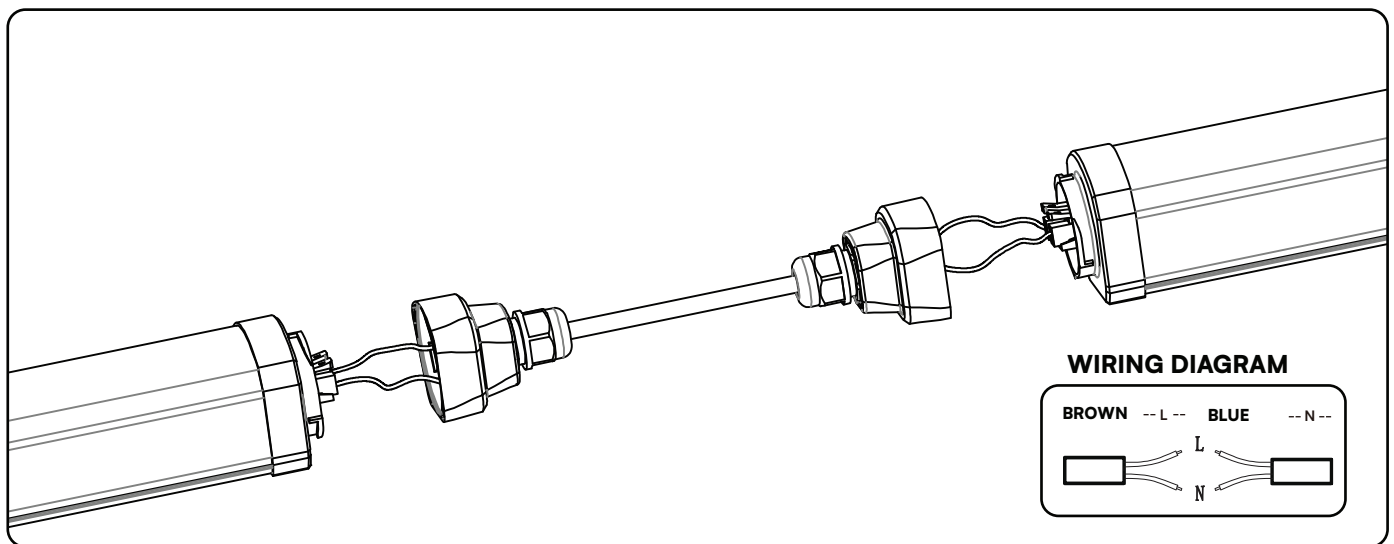

V-TAC WEST EUROPE LTD. IN CASE OF ANY QUERY/ISSUE WITH THE PRODUCT, PLEASE REACH OUT TO US AT:
SUPPORT@V-TAC.EU FOR MORE PRODUCTS RANGE, INQUIRY PLEASE CONTACT OUR DISTRIBUTOR OR NEAREST DEALERS.
V-TAC WEST EUROPE LTD. GROUND FLOOR, 71 LOWER BAGGOT STREET, DUBLIN 02, IRELAND DO2 P593

V-TAC UK LTD. IN CASE OF ANY QUERY/ISSUE WITH THE PRODUCT PLEASE REACH OUT TO US AT
SUPPORT@VTACEXPORTS.COM V-TAC, 5A TUNGSTEN PARK, DOWNS ROAD, WITNEY, OXFORDSHIRE, OX29 0AX